

Installation Instructions

INSTRUCTIONS PERTAINING TO A RISK OF FIRE, OR INJURY TO PERSONS.

IMPORTANT SAFETY INSTRUCTIONS. SAVE THESE INSTRUCTIONS.

(Failure to follow the warnings and instructions on this sheet could result in fire, injury, failure of product, and/or voiding of warranty.)

- Do not touch while lamp is on. Turn off/unplug and allow to cool before replacing lamp.
- Lamp gets HOT quickly! Contact only switch/plug when turning on.
- Do not touch hot lens, faceplate, cover, or body.
- Keep lamp away from materials that may burn.
- Do not touch lamp at any time. Use a soft cloth. Oil from your skin may damage lamp.
- Do not operate with damaged or missing parts.
- Do not disassemble beyond cover/faceplate and cap removal to facilitate lamp and/or accessory installation or replacement.
- Remove any debris accumulated in the cap periodically.
- Do not install within 10 feet of a pool, spa, or fountain.
- Have installed in accordance with all applicable installation codes and standards by a person familiar with the construction, operation, and hazards involved.
- Use only cable properly rated for the application. Cable buried more than 6" must be suitable for direct burial. Direct burial cable may be ordered from Vision3 Lighting.

Notes:

- This fixture should not be mounted in such a way that it is buried or in direct contact with the ground or soil.
- Wiring connections must not be exposed to moisture/water. All wiring must be done in a water tight manner. Failure to do so could result in moisture/water related failure.
- This fixture requires a remote transformer or mount option with integral transformer.
- LED models should only be powered and controlled by compatible transformers and control systems. Contact Vision3 Lighting for approved transformer / controls list. Using non-approved transformers / controls could cause the LED to not operate properly or fail.
- Integral LED options can require up to 13W (10W options) or 15W (12.5W options) during startup, under some circumstances. This must be allowed for when designing system.
- Integral LED options come with a High/Low switch. See 'LED Switching' instructions on next page. Switch will be set to 'High' setting at the factory, unless otherwise specified when ordered.
- Use only Vision3 approved Retrofit MR16 LED options and supplied Heatsink Mount, otherwise LED may overheat and fail.
- LED ratings subject to change without notice. See website or contact V3 for most current info.

Caution! Fixture will be hot if lamp is on. Remove power and allow fixture to cool before performing any adjustments or maintenance.

Installation:

- Unpack the PA7 Bollard Path Light from its shipping container.
- Check to make sure that there are no damaged or missing components.
- Loosen, but don't remove, the four Body Mount Screw's using a 1/8" hex tool.
- Remove the Body from the Mount Base.
- At the desired location, prepare an appropriate size hole in the ground (if using a Stake Mount Base) or create the proper mount hole pattern on the surface (if using a surface mount base).
- Run appropriate power supply cable (not supplied) to the fixture.
- Feed the power supply cable through the bottom of the Stake, if used, and the Mount Base.
- Secure the Mount Base by filling in the hole (if using the Stake Mount Base) or by installing and tightening the mount screws (if using the Surface Mount Base. Mount screws not supplied).
- Connect the socket leads from the Body to the power supply cable using the appropriate connectors per applicable codes. Vision3 recommends using water tight wire nuts suitable for in-grade applications.
- Push the connectors and as much of the wiring as possible down in to the stake or cable hole to keep it protected.
- Slide the Body over the Mount Base and on to the Body Mount Screws, being careful to not pinch or cut any of the wiring.
- Tighten the four Body Mount Screw's using a 1/8" hex tool.
- Install any required lamp or accessories as described below.

Lamp Maintenance:

- Remove power from fixture and let cool before touching. **Caution!**

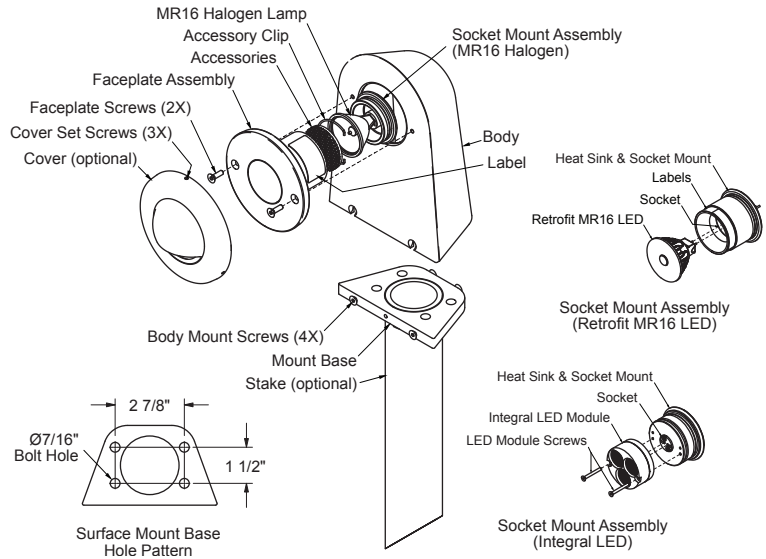

Luminaire may still be hot!

- Loosen the Cover Set Screws (3X) using a 3/32" hex tool (do not remove screws) and remove the Cover from the Faceplate. Note: Not all fixtures have the cover option. In this case, skip this step.
- Loosen the Faceplate Screws (2X) with a 1/8" Hex tool and remove the Faceplate Assembly from the Body. Note: Be careful with the socket leads when removing the Faceplate Assembly.
- Loosen the Faceplate Set Screw using a 3/32" hex tool – do not remove screw!
- Remove the Socket Mount Assembly from the Faceplate Assembly.
- Replace lamp/LED.

For MR16 Halogen Lamp:

- Pull lamp straight out. **Caution! Lamp may still be hot! Be sure lamp has cooled before touching.**
- Inspect socket for any damage.
- Clean inside of fixture and Cap with a clean dry cloth.
- Push new lamp straight in, being careful to align pins. **Note:** Replacement lamp must not exceed ratings on Label.

For Integral LED Module:

- Loosen and remove the LED Module Screws.
- Pull LED straight out. Do not twist or the pins will break off in the socket. **Caution! LED may still be hot! Be sure LED has cooled before touching.**
- Clean the grease off of the Heatsink top surface using a rag dipped in alcohol.
- Inspect the socket for any damage.
- If the replacement LED Module does not come with a thermal transfer pad on the base, apply a thin layer of thermal grease (not

Installation Instructions

INSTRUCTIONS PERTAINING TO A RISK OF FIRE, OR INJURY TO PERSONS.

IMPORTANT SAFETY INSTRUCTIONS. SAVE THESE INSTRUCTIONS.

(Failure to follow the warnings and instructions on this sheet could result in fire, injury, failure of product, and/or voiding of warranty.)

supplied) to the surface of the Heatsink that will contact the bottom of the LED Module.

- f. Align the pins on the LED Module with the socket and push straight in. Do not twist or push in at an angle or the pins may be damaged.
- g. Install and tighten the LED Module Screws. **Caution!** Over tightening of screws could crack the LED Module case.

For Retrofit MR16 LED Lamp:

- a. Pull lamp straight out. **Caution! Lamp may still be hot! Be sure lamp has cooled before touching.**
 - b. Inspect socket for any damage.
 - c. Clean inside of fixture and Cap with a clean dry cloth.
 - d. Push new lamp straight in, being careful to align pins. Make sure Retrofit MR16 Lamp fully contacts Heatsink Mount, otherwise lamp may overheat and fail prematurely. **Note:** Replacement lamp must not exceed ratings on Label. Only use Vision3 approved Retrofit MR16 Lamp and supplied Heatsink Mount, otherwise LED may overheat and fail.
7. Re-install Socket Mount Assembly in to Faceplate Assembly.
 8. Tighten Faceplate Set Screw with the 3/32" hex tool so that is just bottoms out.
 9. Insert the Faceplate Assembly in to the Body. Note: Make sure the wiring is not kinked or pinched in any way.
 10. Use the Faceplate Screws (2X) to attach the Faceplate Assembly to the Body. Notes: Skip the next steps if your fixture does not have a cover option:
 11. Slide the Cover over the Faceplate as far as it will go, and properly orient. Note: Eyelid should not be pointed up as it will fill with water and debris.
 12. Gently tighten each Cover Set Screw against Faceplate.

LED Switching (on certain models):

1. Remove the Faceplate Assembly to gain access to the Integral LED Module as explained in Lamp Maintenance steps 1 thru 5.
2. Inspect for damage. Replace any damaged parts, if necessary.
3. Clean inside of fixture with a clean, damp cotton cloth.
4. Find LED High/Low Switch on side of Integral LED Module.
5. Using a pin, small nail, etc, flip the switch in the desired direction. See the LED Module Switch sketch for which direction corresponds to which setting.
6. Re-assemble as explained in Lamp Maintenance steps 7 thru 12.

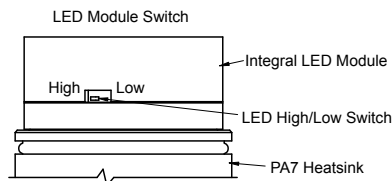

Accessory Maintenance:

1. Remove the Faceplate Assembly to gain access to the accessories, as explained in Lamp Maintenance steps 1 thru 5.
2. Remove Accessory Clip from Cap.
3. Carefully remove Accessories from Cap, if any.
4. Inspect Cap, Accessories, and Clip for damage. Replace if necessary.
5. Clean Cap and Accessories with a clean, damp cotton cloth.
6. Carefully install new Accessories into Cap (Cap may hold up to 2 Accessories).
7. Compress Clip and push into Cap until it holds Accessories tightly in Cap.
8. Re-assemble as explained in Lamp Maintenance steps 7 thru 12.